



High-Temperature Heat Pump Symposium



**Steam production with piston compressor based heat
pump**

-24.1.2021-

Agenda

- **ThermBooster Heat Pump**
- direct steam production
- Project example



ThermBooster Compressor



SPH – High temperature - Piston compressor

- Data
 - 4 Cylinders
 - 576 m³/h theoretical displacement
 - 35 bar/18 bar HD/ND
 - Open design
 - For engines from 110 kW to 200 kW
- Specifically developed for use in ultra-high temperature heat pumps
- Optimized for HFOs and HCs
- Optimized valve system and optimal temperature control ensures high efficiency
- Robust industrial design for a long service lifetime and low maintenance costs
- Integrated oil conditioning
- Very good partial load capability thanks to speed-controlled operation
- Use of premium efficiency motors (IE5) in combination with industrial inverter systems

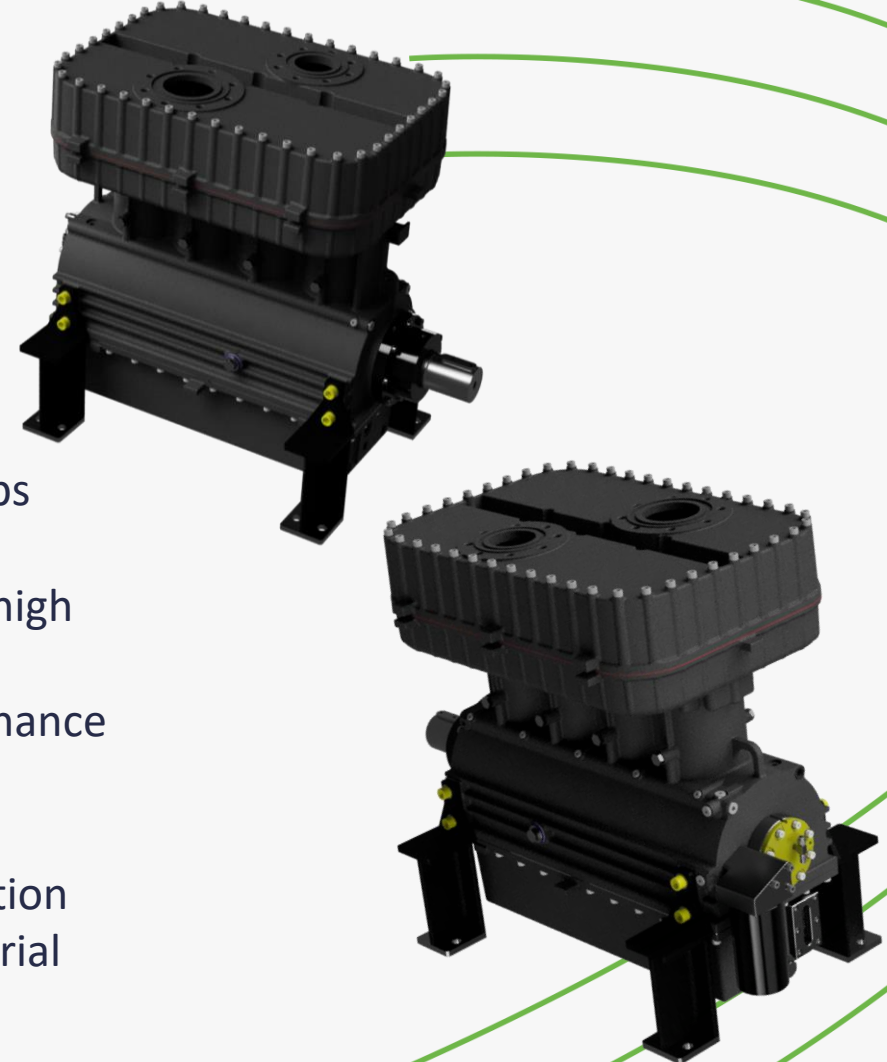

ThermBooster Building Kit

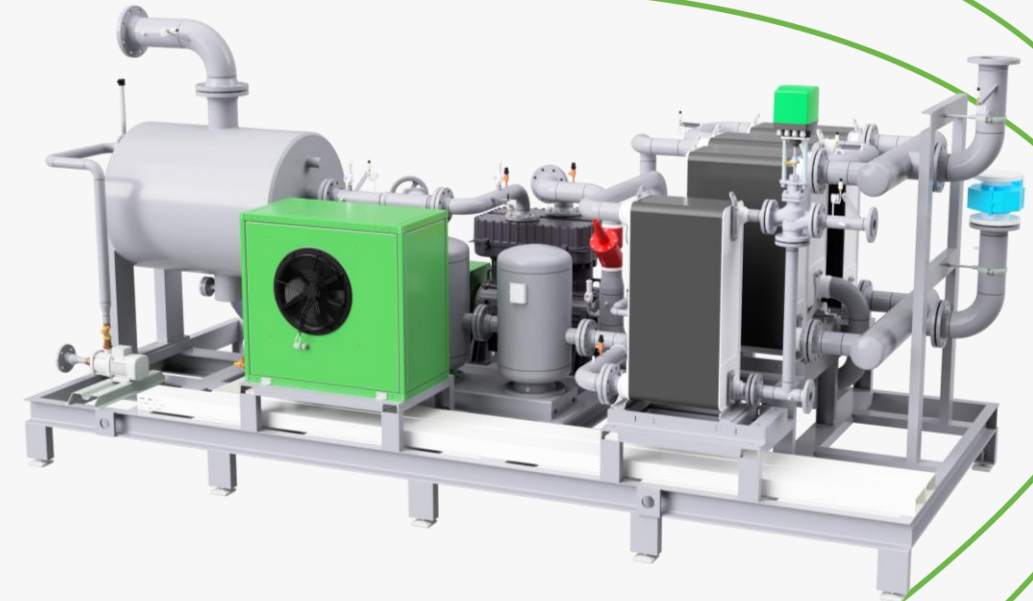
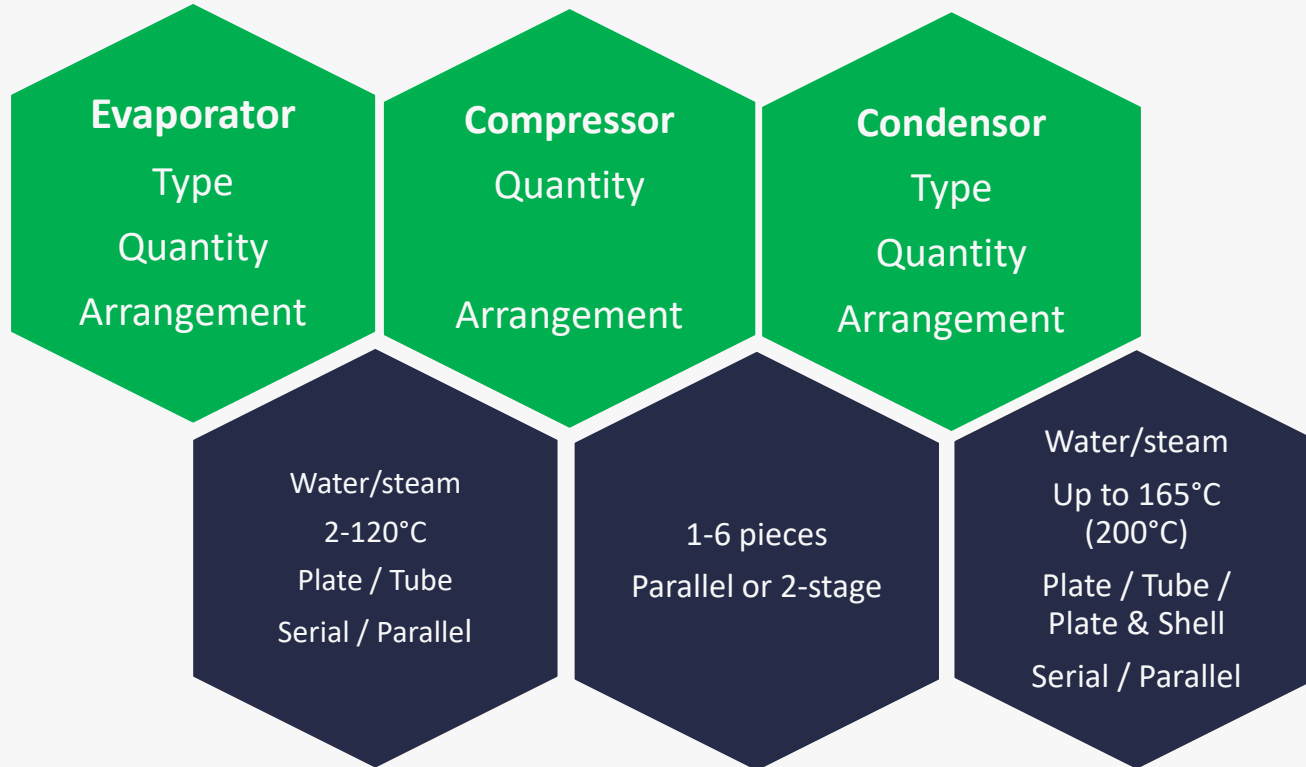

Temperature range:

- up to 165°C with HFO (saturated steam 6 bar abs)
- Potential >200°C with HC (saturated steam >12 bar abs)

Agenda

- ThermBooster Heat Pump
- **direct steam production**
- Project example



Direct steam production



- Direct production of saturated steam in the condenser of the heat pump
 - Highest efficiency
 - No further components / consumer (circulating pump,...)

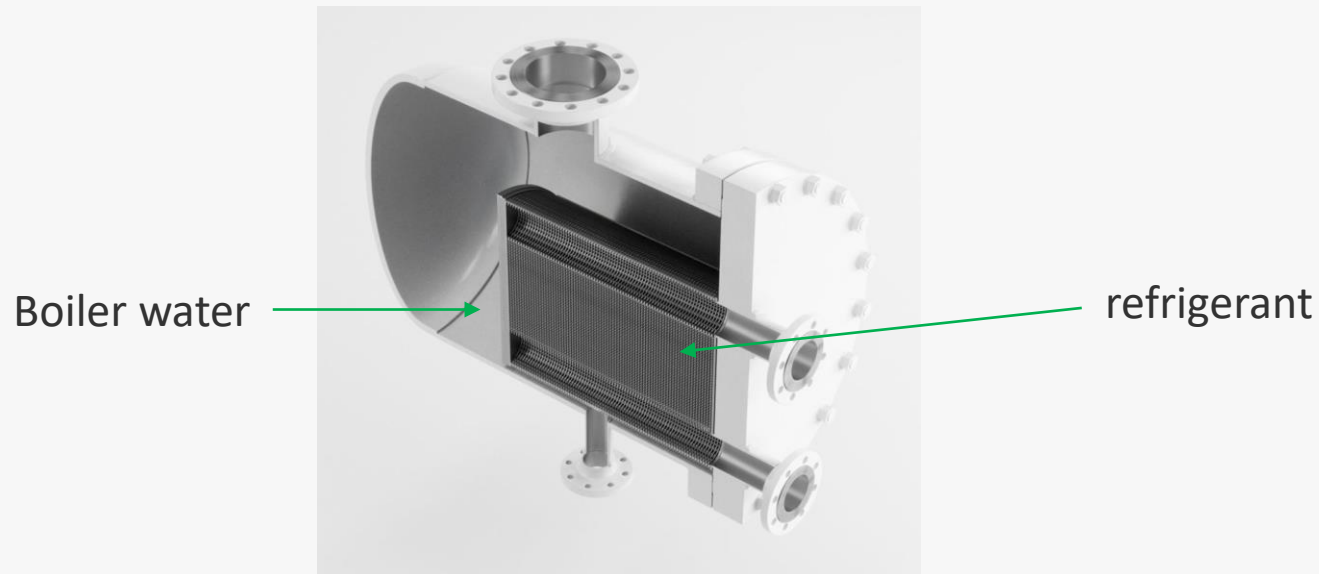

source: Vahterus



Direct steam production

constant operating points

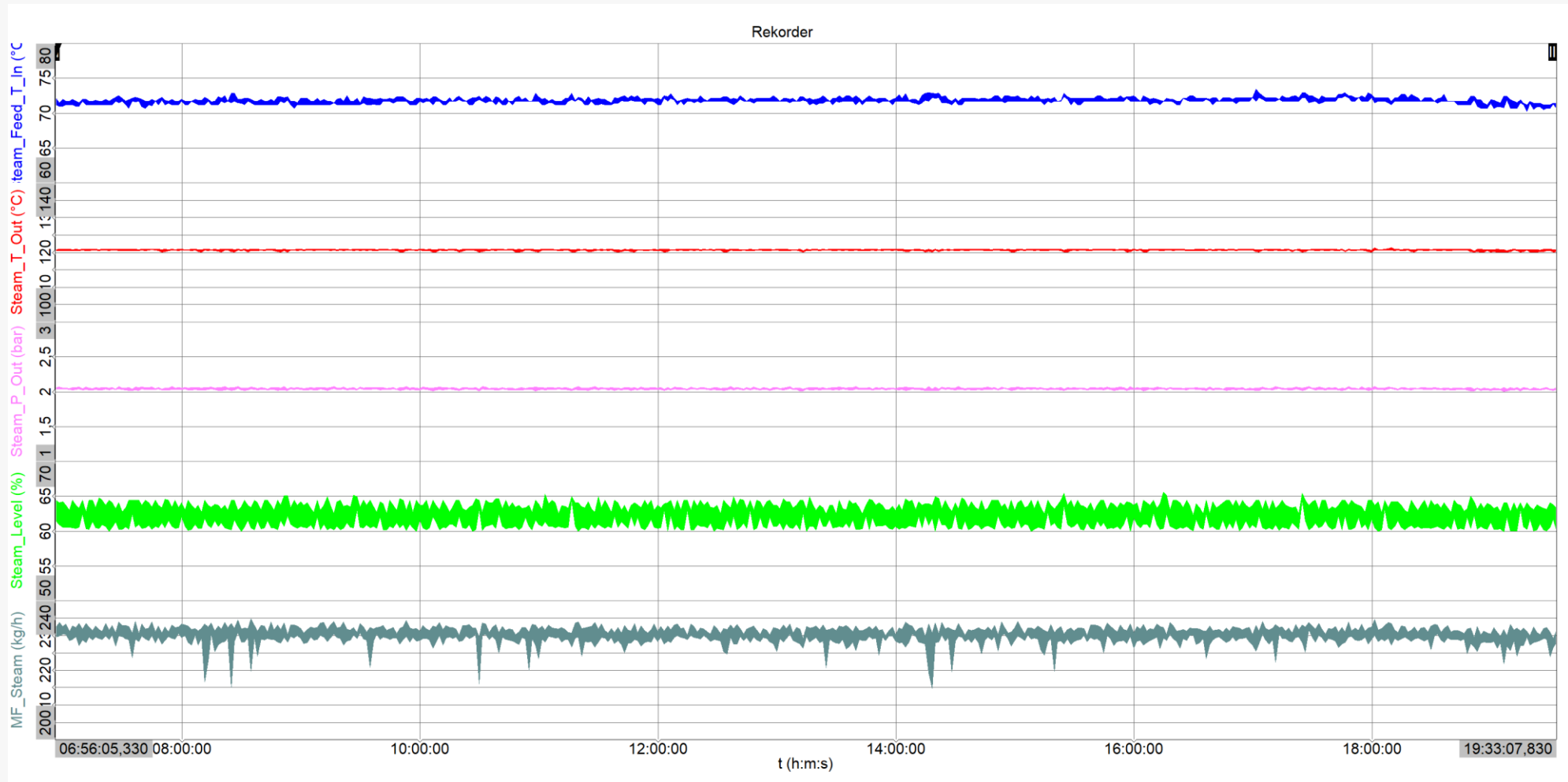

Direct steam production

constant operating points

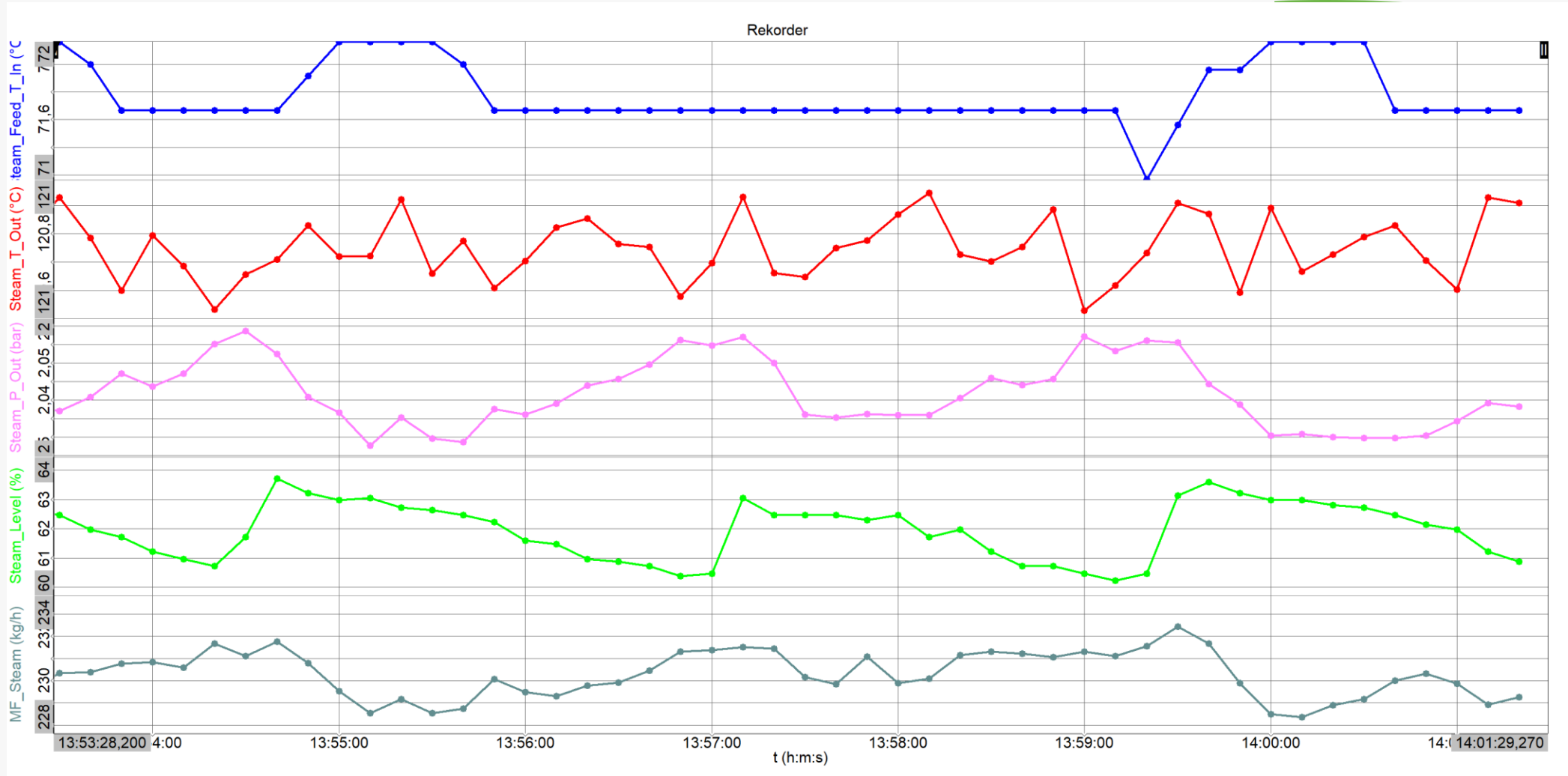

Direct steam production

constant operating points

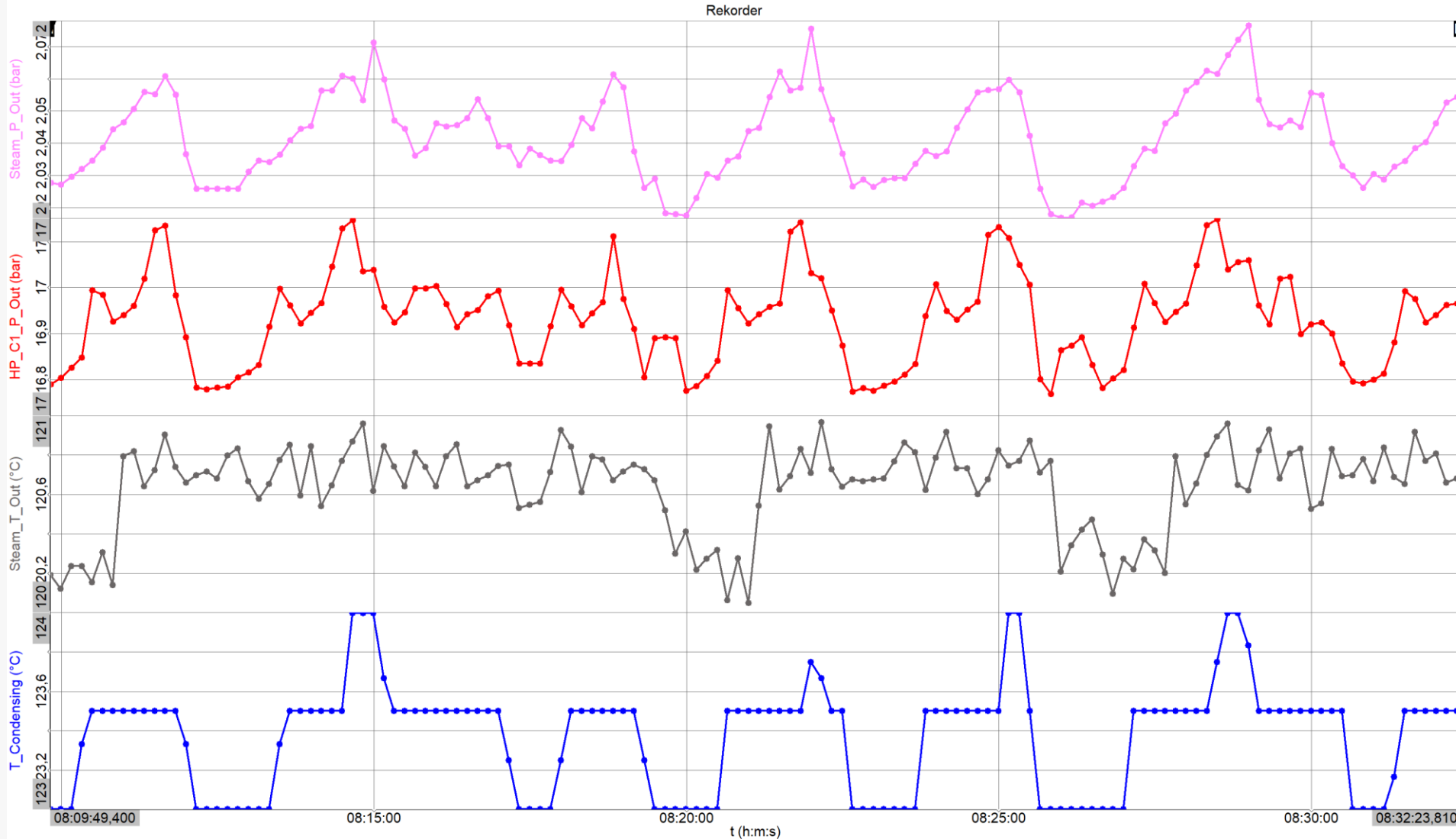

Direct steam production

Changing conditions

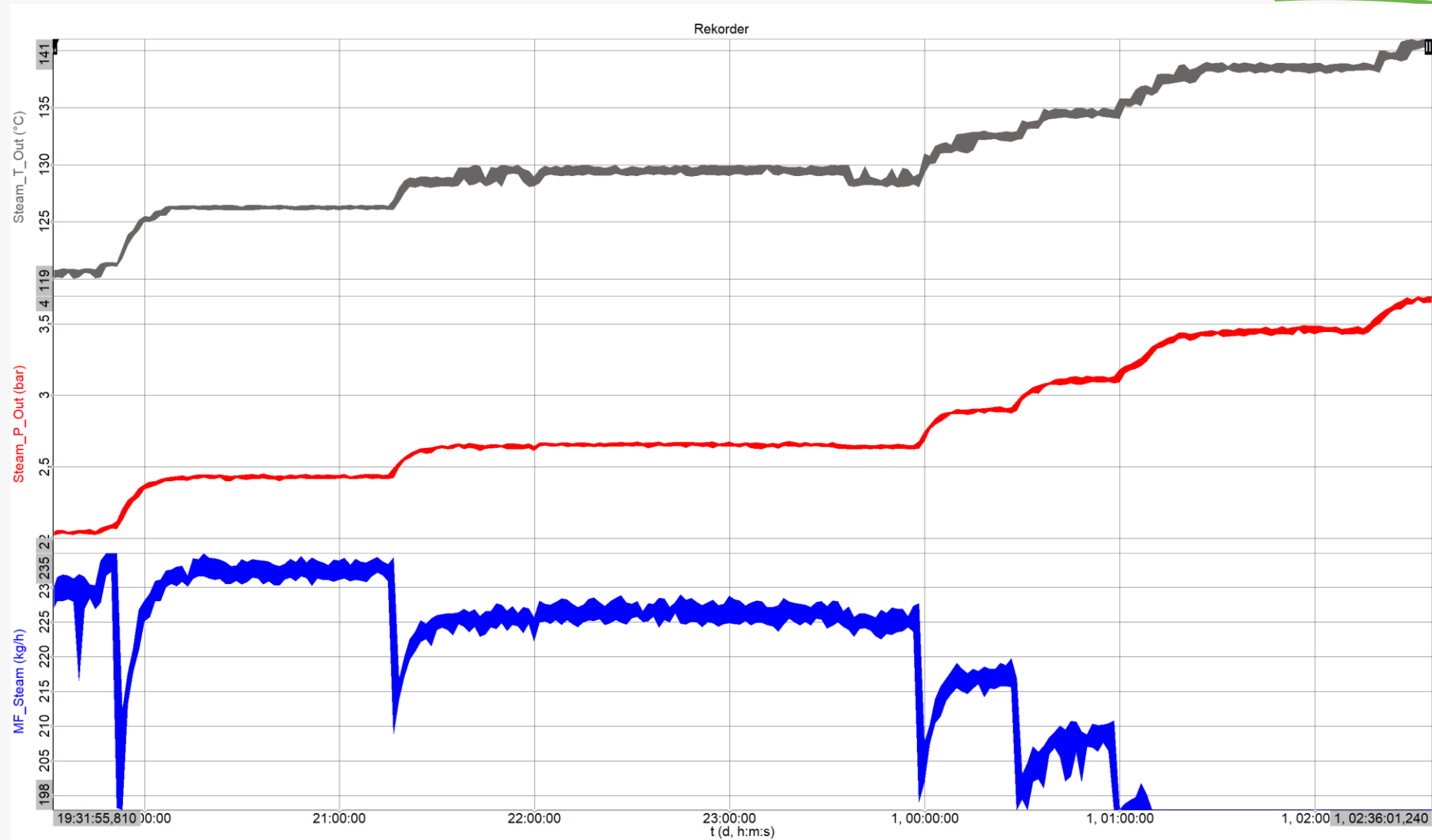

Direct steam production

Changing conditions

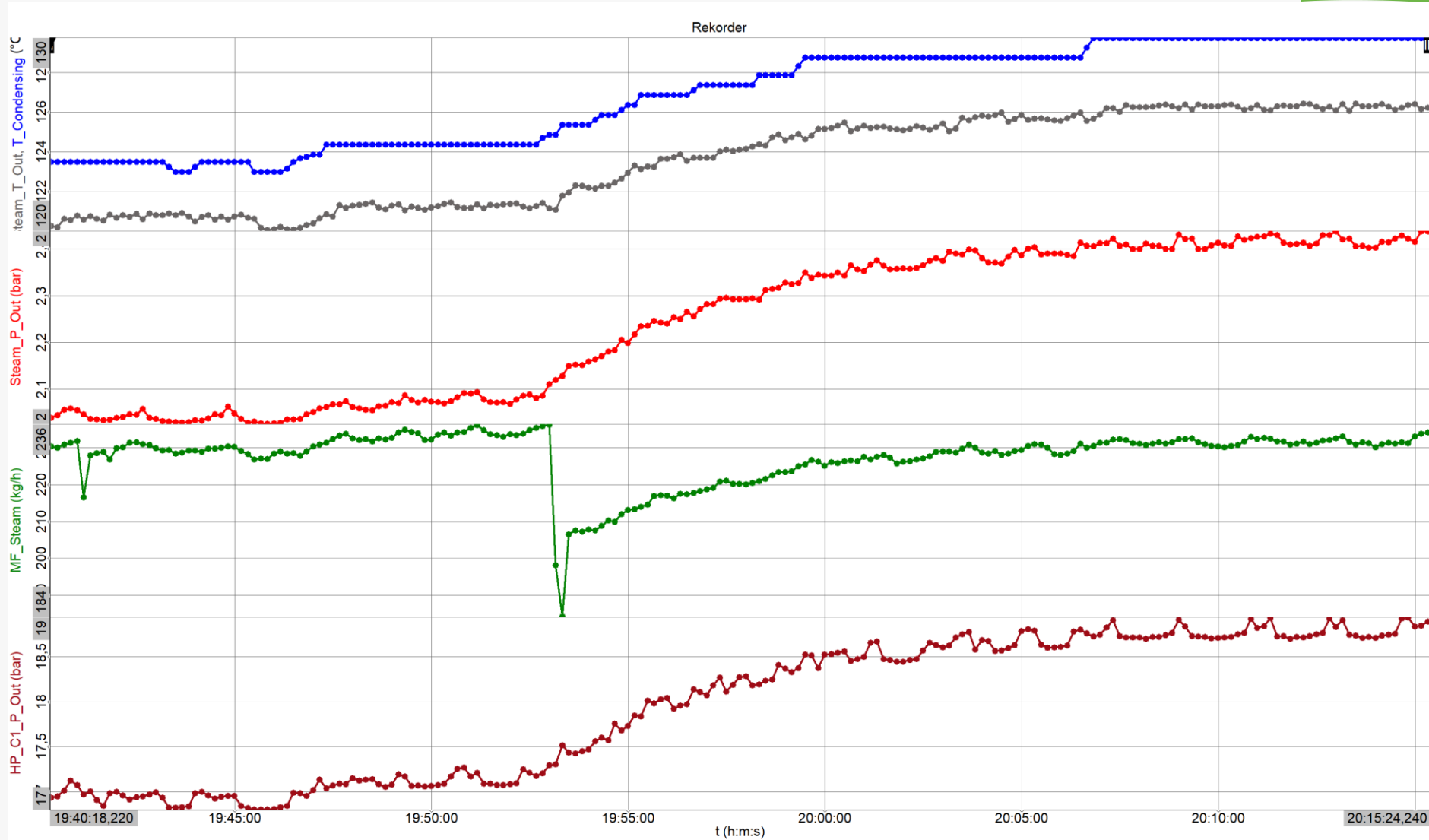

Direct steam production

Changing conditions

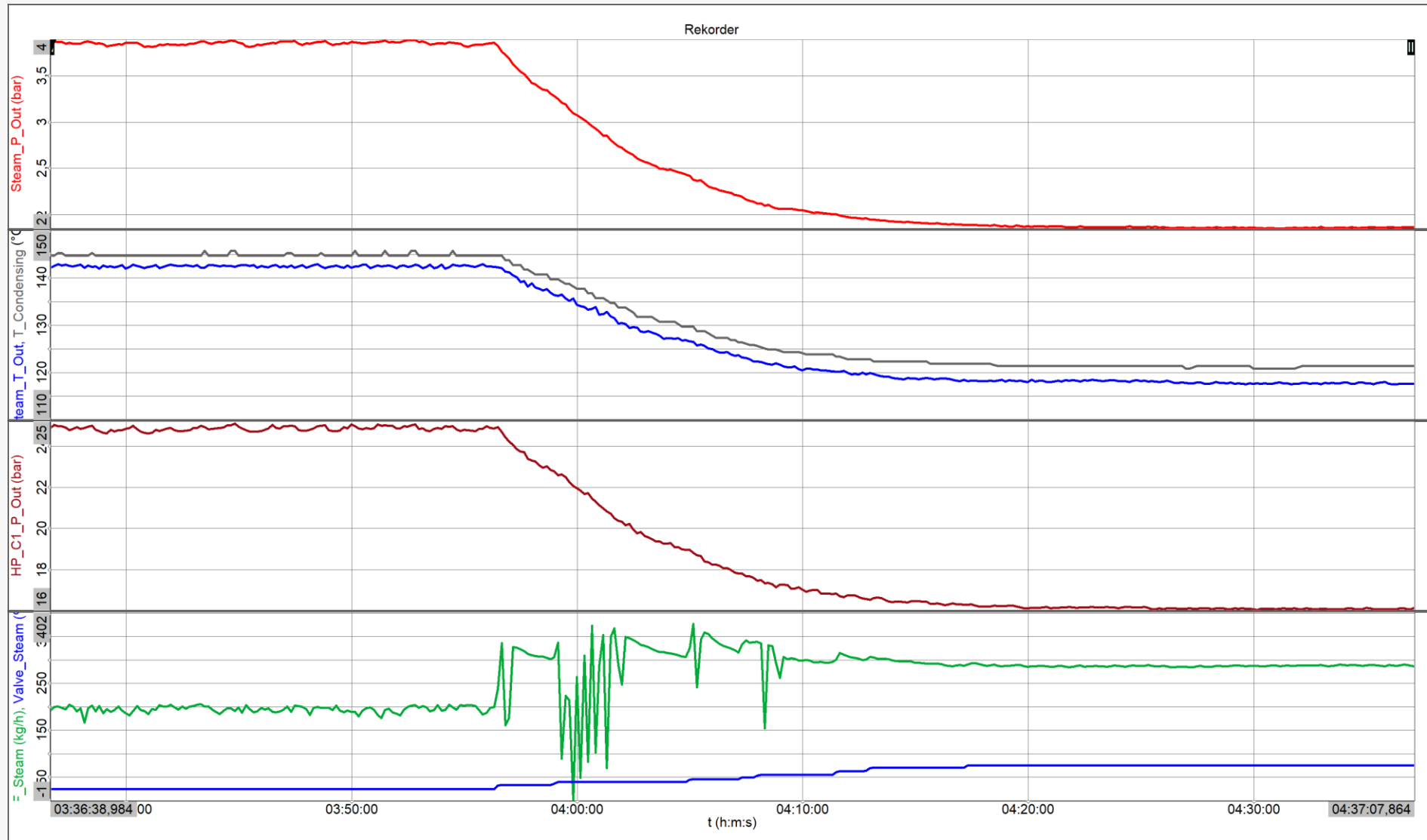

Direct steam production

Conclusion



The production of saturated steam directly in the condenser of a heat pump is quite easy to realize.

- Transient conditions are also controllable, hardly any influence on the refrigeration circuit
- Pressure increases lead to a short-term drop in steam production
- Pressure drops lead to increased vaporization
- Very high efficiency possible due to small gap between steam temperature and working fluid condensation temperature

Agenda

- ThermBooster Heat Pump
- direct steam production
- **Project example**



Project

Push2Heat



High-Temperature
Heat Pump Symposium



DEMO 1: Paper industry

Felix Schoeller Group (Germany)

Location	Weissenborn, Germany
Plant owner	Felix Schoeller Group
Technology	Heat pump cascade, 2 stages
Waste heat source	Exhaust heat from the paper machine dryer: water glycol circuit from the exhaust humid air heat recovery circuit (46°C/41°C)
Heat supply	Low pressure steam at 2,2 bar(a) (123 °C)
HThP Unit	1180 kW (1800kg/h) Sums up to around 13000 to 15000 to/a
Power consumption	517 kW
COP	2,3
Refrigerants	R515B/R1233zd
Installation	Container next to production building

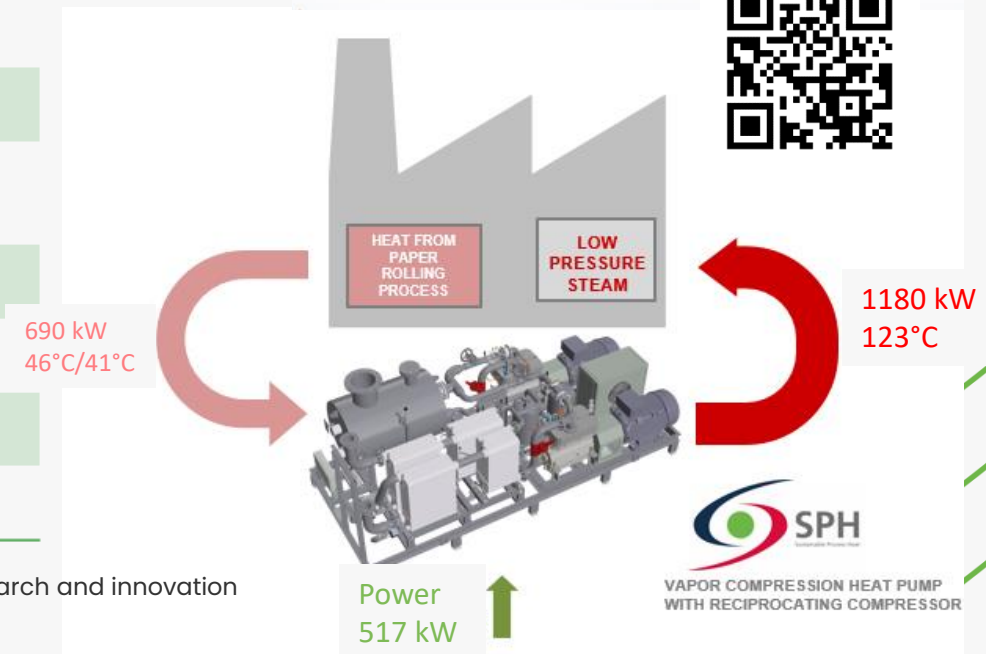
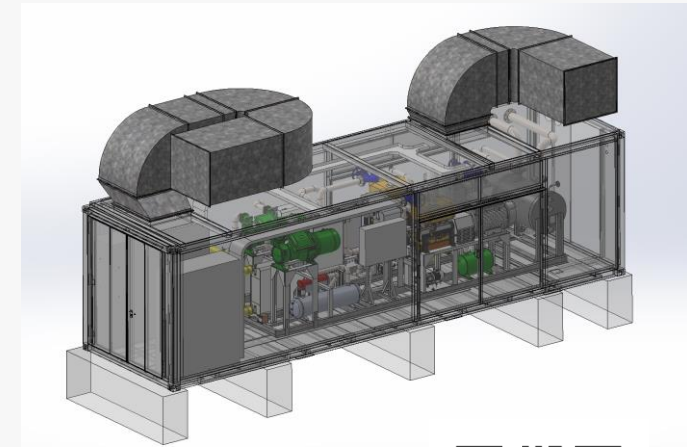

This project has received funding from the European Union's Horizon Europe research and innovation programme under grant agreement No. 101069689 (PUSH2HEAT).

Project



AHEAD: Advanced heat pump demonstrator

- Steam generating SPH heat pump, using Butane as refrigerant
- Combination with a mechanical vapor recompression technology (MVR)
- Heat production: 1,7 MW
- Heating and cooling supply exclusively using natural refrigerants
- Installation planned for end of 2024

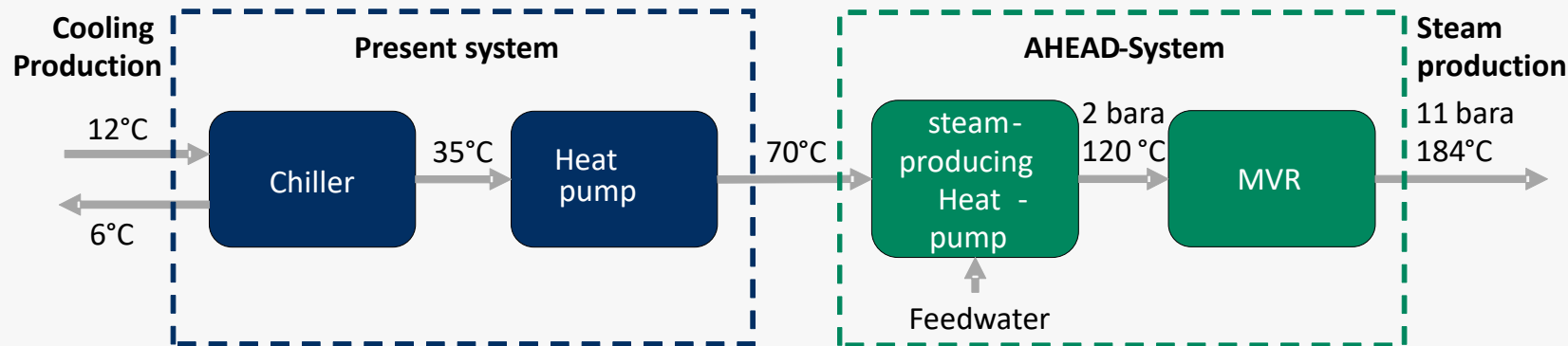

THANK YOU



High-Temperature
Heat Pump Symposium



Hot, Efficient, Green

Tim Hamacher
tim.hamacher@spheat.de
+49 2206 9050661